

DYNASET

POWERED BY HYDRAULICS

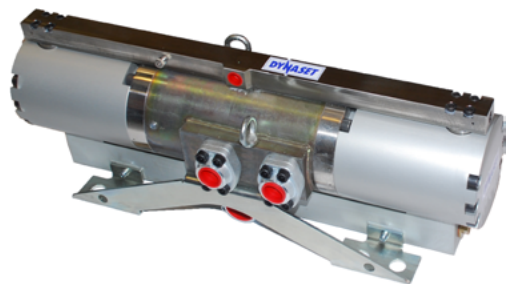
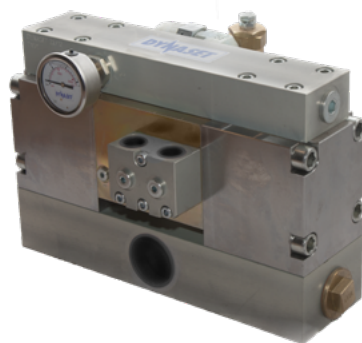
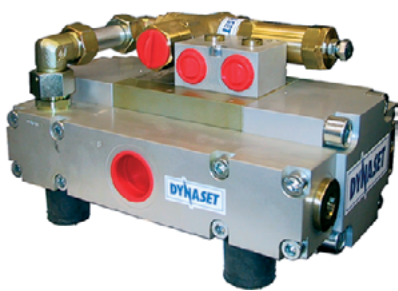

DATA SHEET

HIGH PRESSURE WATER PUMPS

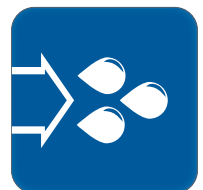

09/18
rev 1.3

HPW 90 /150-85

HPW 130 /180-140

HPW 180 /90-115

HPW 200 /30-45

HPW 220 /50-70

HPW 250 /30-40

HPW 300 /300-350

HPW 320 /75-125

HPW 360 /220-360

HPW 420 /20-50

HPW 460 /50-115

HPW 520 /30-85

HPW 800 /30-140

HPW 1000 /30-140

HPW 1200 /100-440

HPW 1600 /15-140

HIGH PRESSURE WATER PUMPS

DYNASET HPW high pressure water pump transforms the hydraulic power of a work machine effectively into high pressure water power. Because of high pressure, the pump gives great water power with a small amount of water. To ease up the use of the pump; pump is self-priming, requiring no feed pressure.

Small size, light weight, durable construction and low water consumption make the HPW pump very cost effective. The patented design of the pump is completely free of rotating parts. Compared to other pumps of the same power, the HPW pump is only fraction in size. It can be installed practically in any space in the work machine. The power range of pumps available covers all needs.

The HPW pump is an excellent tool in daily cleaning work and other works, where reliable high pressure water is needed. It is also powerful enough for industrial applications, dust suppression, fire fighting, hydro scaling and other demanding applications.

DIMENSIONS

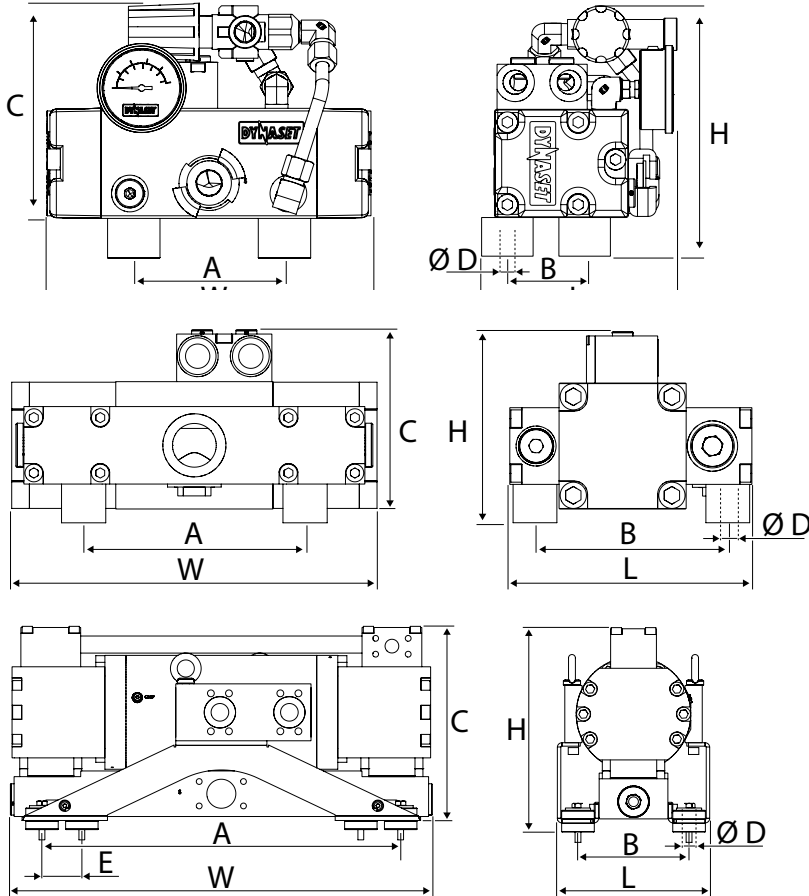

MODEL	DIMENSIONS, mm (in)								WEIGHT kg (lbs)
	L	W	H	A	B	C	D	E	
HPW 90 /150-85-PA	175 (6.9)	345 (13.6)	250 (9.8)	252 (9.9)	95 (3.7)	250 (9.8)	M10	-	31 (68.3)
HPW 130 /180-140-PA	175 (6.9)	400 (15.7)	270 (10.6)	250 (9.8)	95 (3.7)	270 (10.6)	M10	-	35 (77.2)
HPW 180 /90-115-PA	240 (9.4)	330 (13.0)	175 (6.9)	200 (7.9)	175 (6.9)	160 (6.3)	M10	-	28 (61.7)
HPW 200 /30-45-ST	160 (6.3)	245 (9.6)	165 (6.5)	115 (4.5)	60 (2.4)	135 (5.3)	M8	-	8 (17.6)
HPW 220 /50-70-PA	170 (6.7)	280 (11.0)	185 (7.2)	126 (4.7)	106 (4.2)	153 (6.0)	M8	-	18 (39.6)
HPW 250 /30-40-ST	167 (6.6)	238 (9.4)	179 (7.0)	115 (4.5)	60 (2.4)	146 (5.7)	M8	-	11 (24.3)
HPW 300 /300-350*	270 (10.6)	745 (29.3)	360 (14.2)	630 (24.8)	194 (7.5)	340 (13.4)	16 (0.6)	70 (2.8)	170 (374.7)
HPW 320 /75-125 *	250 (9.8)	344 (13.5)	282 (11.1)	155 (6.1)	155 (6.1)	220 (8.7)	M8	-	32 (70.4)
HPW 360 /220-360*	270 (10.6)	745 (29.3)	360 (14.2)	630 (24.8)	194 (7.5)	340 (13.4)	16 (0.6)	70 (2.8)	170 (374.7)
HPW 420 /20-50	160 (6.3)	245 (9.6)	155 (6.1)	115 (4.5)	60 (2.4)	125 (4.9)	M8	-	16 (35.2)
HPW 460 /50-115	195 (7.7)	314 (12.2)	197 (7.8)	155 (6.1)	155 (6.1)	167 (6.6)	M8	-	32 (70.5)
HPW 520 /30-85	140 (5.5)	290 (11.4)	175 (6.9)	115 (4.5)	80 (3.1)	145 (5.7)	M8	-	22 (48.5)
HPW 800 /30-140*	195 (7.6)	340 (13.3)	195 (7.6)	110 (4.3)	65 (2.6)	165 (6.5)	M8		39 (85.9)
HPW 1000 /30-140*	168 (6.6)	379 (15.6)	194 (7.6)	110 (4.3)	64 (2.5)	164 (6.5)	M8		39 (85.9)
HPW 1200 /100-440*	265 (10.4)	915 (36)	350 (13.8)	630 (24.8)	194 (7.5)	335 (13.2)	16 (0.6)	70 (2.8)	177 (390.2)
HPW 1600 /15-140*	195 (7.6)	405 (15.9)	160 (6.3)	155 (6.1)	155 (6.1)	120 (4.7)	M10	-	36 (79.3)

* Without Unloader valve

PARAMETERS

		HPW 200 /30-45	HPW 250 /30-40	HPW 420 /20-50	HPW 220 /50-70	HPW 90 /150-85	HPW 520 /30-85	HPW 180 /90-115	
DISCHARGE CHARACTERISTICS									
Pumping fluid flow max.	l/min (gpm)	30 (7.9)	30 (7.9)	20 (5.3)	50 (13.2)	150 (39.6)	30 (7.9)	90 (23.8)	
Pressure max.	bar (psi)	200 (2900)	250 (3600)	420 (6100)	220 (3200)	90 (1300)	520 (7500)	180 (2600)	
Power	kW	10	12,5	14	18,5	22,5	26	27	
Water/hydraulic pressure ratio		1,18	1,18	2,12	1,26	0,52	2,62	1,12	
HYDRAULIC POWER REQUIREMENTS									
Oil flow max.	l/min (gpm)	40 (10.6)	40 (10.6)	50 (13.2)	70 (18.5)	85 (22.5)	85 (22.5)	115 (30.4)	
Operating pressure	Δp . bar (psi)	210 (3000)	250 (3600)	210 (3000)	210 (3000)	210 (3000)	210 (3000)	210 (3000)	
Pressure max.	bar (psi)	210 (3100)	260 (3800)	220 (3200)	210 (3100)	210 (3100)	250 (3600)	210 (3100)	
PUMPING FLUID REQUIREMENTS									
Suction head max	m (ft)	3 (9.8)							
Feed pressure	bar (psi)	-0,3...16 (-4.4...232)							
Water filter	mesh	80 or better							
HYDRAULIC FLUID REQUIREMENTS									
Viscosity	cSt	10-200 / optimum 25-35							
Temperature *	°C (°F)	max. 70 (158)							
Filter ratio	µm	25 or better							
Cooling capacity requirement	kW	2	2,5	2	3	4	4	6	

Gallons are U.S. liquid gallons

* Depending on hydraulic fluid.



HIGH PRESSURE WATER PUMPS

DATA SHEET

HPW 460 /50-115	HPW 320 /75-125	HPW 130 /180-140	HPW 800 /30-140	HPW 1600 /15-140	HPW 1000 /30-140	HPW 360 /220-360	HPW 300 /300-350	HPW 1200 /100-440
50 (13.2)	75 (19.8)	180 (47.5)	30 (7.9)	15 (4.0)	30 (7.9)	220 (58.0)	300 (79.2)	100 (26.4)
460 (6700)	320 (4600)	130 (1900)	800 (11603)	1600 (23200)	1000 (14500)	360 (5200)	300 (4300)	1200 (17400)
38	40	39	40	40	50	132	150	200
2,03	1,5	0,68	4	7,87	4	1,5	1,06	4
115 (30.4)	125 (33.0)	140 (37.0)	140 (37.0)	140 (37.0)	140 (37.0)	360 (95.0)	350 (92.5)	440 (116.0)
240 (3500)	240 (3500)	240 (3500)	210 (3100)	230 (3300)	260 (3800)	250 (3600)	350 (5100)	300 (4300)
250 (3600)	250 (3600)	250 (3600)	210 (3100)	230 (3300)	280 (4100)	250 (3600)	350 (5100)	350 (5100)
3 (9.8)			2 (6.5)	-	-	3 (9.8)		-
-0,3...16 (-4.4...232)			-0,2...16 (-2.9...232)	3...16 (43.5...232)	3...20 (43.5...290)	-0,3...16 (-4.4...230)	-0,3...16 (-4.4...232)	3...16 (43.5...232)
80 or better				625 or better		80 or better		625 or better
10-200 / optimum 25-35								
max. 70 (158)								
25 or better								
5	6	6	6	6	8	25	30	35

CONNECTION PORTS

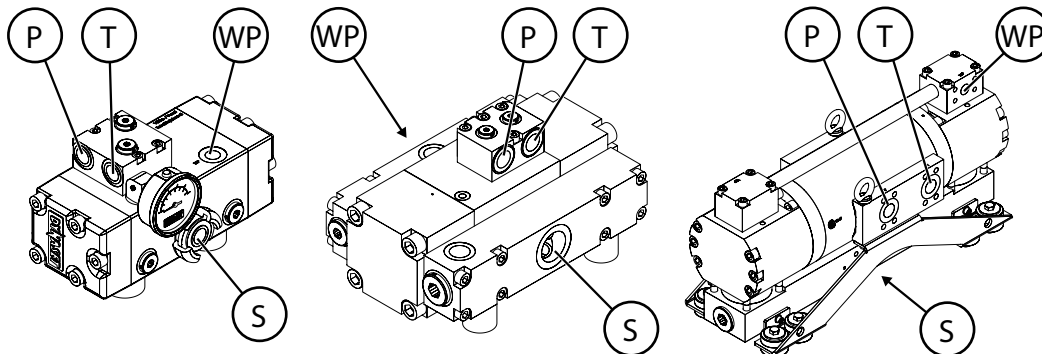

MODEL	PRESSURE LINE	RETURN LINE	SERVICE LINE	WATER OUTPUT	WATER INPUT
	P	T	CMP	WP	S
HPW 90 /150-85	BSP 3/4"	BSP 3/4"	BSP 1/8"	BSP 1"	BSP 2"
HPW 130 /180-140	BSP 3/4"	BSP 3/4"	BSP 1/8"	BSP 1"	BSP 2"
HPW 180 /90-115	BSP 3/4"	BSP 3/4"	BSP 1/8"	BSP 3/4"	BSP 1 1/4"
HPW 200 /30-45	BSP 1/2"	BSP 1/2"	-	BSP 3/8"	BSP 3/4"
HPW 220 /50-70	BSP 3/4"	BSP 3/4"	-	BSP 1/2"	BSP 1"
HPW 250 /30-40	BSP 1/2"	BSP 1/2"	-	BSP 3/8"	BSP 3/4"
HPW 300 /300-350	SAE 6000 1 1/4"	SAE 6000 1 1/4"	BSP 1/8"	SAE 6000 1" (BSP 3/4")	SAE 3000 2"
HPW 320 /75-125	BSP 3/4"	BSP 3/4"	-	BSP 1/2"	BSP 1 1/4"
HPW 360 /220-360	SAE 6000 1 1/4"	SAE 6000 1 1/4"	BSP 1/8"	SAE 6000 1" (BSP 3/4")	SAE 3000 2"
HPW 420 /20-50	BSP 1/2"	BSP 1/2"	-	BSP 3/8"	BSP 3/4"
HPW 460 /50-115	BSP 3/4"	BSP 3/4"	BSP 1/8"	BSP 1/2"	BSP 1"
HPW 520 /30-85	BSP 3/4"	BSP 3/4"	BSP 1/8"	BSP 3/8"	BSP 3/4"
HPW 800 /30-140	BSP 3/4"	BSP 3/4"	BSP 1/8"	BSP 3/8"	BSP 3/4"
HPW 1000 /30-140	BSP 3/4"	BSP 3/4"	BSP 1/8"	MP 9/16"	BSP 3/4"
HPW 1200 /100-440	SAE 6000 1 1/4"	SAE 6000 1 1/4"	BSP 1/8"	MP 3/4"	SAE 3000 2"
HPW 1600 /15-140	BSP 3/4"	BSP 3/4"	BSP 1/8"	HP 1/4"	BSP 1/2"



HIGH PRESSURE WATER PUMPS

DATA SHEET



Menotie 3
FI-33470 Ylöjärvi, Finland
tel: +358 3 3488 200
info@dynaset.com



ELECTRICITY

HG Hydraulic Generator
HGV POWER BOX Variable Hydraulic Generator System
HGV Variable Hydraulic Generator System
HWG Hydraulic Welding Generator
HGG Hydraulic Ground Power Generator



HIGH PRESSURE WATER

HPW Hydraulic High Pressure Water Pump
HPW Hydraulic Power Washer
KPL High Pressure Street Washing Unit
HPW-DUST High Pressure Dust Suppression System
PPL High Pressure Pipe Cleaning Unit
HPW-FIRE High Pressure Firefighting System
FP Fire Fighting Piercing Kit
HDF Hydraulic Drilling Fluid Pump
JPL High Pressure Bin Washing System
HSP Hydraulic Submersible Pump



COMPRESSED AIR

HK Hydraulic Piston Compressor
HKL Hydraulic Rotary Vane Compressor
HKR Hydraulic Screw Compressor



MAGNET POWER

HMG PRO Hydraulic Magnet Generator
MAG Lift Magnet
HMAG PRO Hydraulic Magnet



VIBRATION

HVB Hydraulic Vibra
HVD Hydraulic Directional Vibra
HRC Hydraulic Reversal Cylinder



POWER BOOSTING

HPI Hydraulic Pressure Intensifier
HPI-C Hydraulic Pressure Intensifier for Cylinder



KNOW-HOW

Hydraulic Power Take-off (PTO)
Hydraulic Power Unit Technology
De-Icing Technology
Installation Valves
HHK Hydraulic Grinder
HV/HVY Hydraulic Winch / Winch Unit

www.dynaset.com

