

DYNASET

POWERED BY HYDRAULICS



DATA SHEET

HYDRAULIC PISTON COMPRESSORS



rev 1.1

HK 450 /8-14

HK 1000 /12-35

HYDRAULIC PISTON COMPRESSOR

DYNASET HK hydraulic piston compressors are compact and integrated all-in-one units, especially designed for mobile installation. The only power source needed is a hydraulic system of base machine which provides compressor the required hydraulic flow and pressure.

HK compressor converts the hydraulic power into high quality compressed air and it can be installed in almost any working machine. HK compressors are used to power for example pneumatic tools, filling tires and cleaning equipment.

The trouble free hydraulic compressor starts reliably and needs no extra fuel. It will serve a long time – with far less need for maintenance compared to a towed compressor unit of same power level.

HK compressors are designed to meet regular modern compressed air demands.

DIMENSIONS

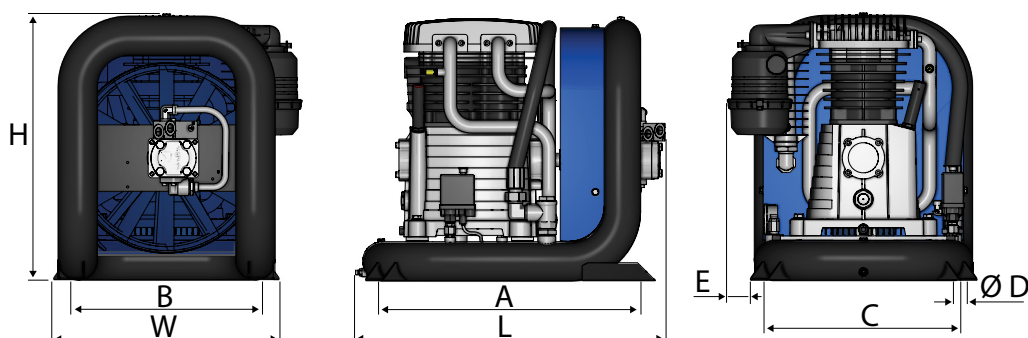

MODEL		DIMENSIONS, mm (in)								WEIGHT kg (lbs)
		L	W	H	A	B	C	D	E	
HK 450 /8-14	Y	508 (20.0)		423 (16.7)						
	S	496 (19.5)		446 (17.6)						
	S-Y	499 (19.6)	422 (16.6)	423 (16.7)	374 (14.7)	350 (13.8)	350 (13.8)	11 (0.43)	-	35 (77.2)
	PNE	517 (20.4)		446 (17.6)						
	PNE-Y	527 (20.7)		423 (16.7)						
HK 1000 /12-35		710 (28.0)	490 (19.3)	605 (23.8)	610 (24.0)	430 (16.9)	430 (16.9)	13 (0.51)	60 (2.36)	80 (176.4)

PARAMETERS

		HK 450 /8-14	HK 1000 /12-35
DISCHARGE CHARACTERISTICS			
Flow rate max. at ref. conditions *	l/min (gal)	450 (118.9)	1000 (264.2)
Pressure max.	bar (psi)	8 (116)	12 (174)
Compressed air connection	AP	BSP 1/2"	BSP 1"
Frame reservoir	l (gal)	4,27 (1.13)	14 (3.70)
HYDRAULIC POWER REQUIREMENTS			
Oil flow min.	l/min (gal)	10 (2.64)	12 (3.17)
Oil flow nom.	l/min (gal)	15 (3.96)	35 (9.25)
Oil flow max.	l/min (gal)	35 (9.25)	50 (13.20)
Pressure at nominal flow	bar (psi)	130 (1885)	210 (3046)
Pressure max.	bar (psi)	210 (3046)	230 (3336)
Pressure when unloaded	bar (psi)	67 (972)	100 (1450)
HYDRAULIC FLUID REQUIREMENTS			
Viscosity	cSt	10-200 / optimum 25-35	
Temperature **	° C (° F)	max. 70 (158)	
Filter ratio	µm	25 or better	
Cooling capacity requirement **	kW	2	4

Gallons are U.S. liquid gallons

* According to ISO 1217 (19.6) at discharge pressure of 6 bar

** Depending on hydraulic fluid.

*** Minimum oil cooling capacity for HK compressor on base machine.

CONNECTION PORTS

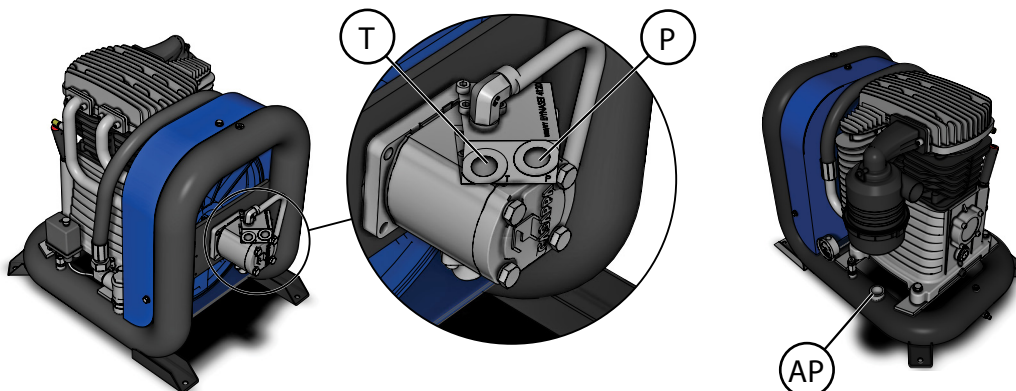

MODEL	PRESSURE LINE	RETURN LINE	AIR OUTPUT
	P	T	AP
HK 450 /8-14	BSP 1/2"	BSP 1/2"	BSP 1/2"
HK 1000 /12-35	BSP 1/2"	BSP 1/2"	BSP 1"



Menotie 3
FI-33470 Ylöjärvi, Finland
tel: +358 3 3488 200
info@dynaset.com



ELECTRICITY

HG Hydraulic Generator
HGV POWER BOX Variable Hydraulic Generator System
HGV Variable Hydraulic Generator System
HWG Hydraulic Welding Generator
HGG Hydraulic Ground Power Generator



HIGH PRESSURE WATER

HPW Hydraulic High Pressure Water Pump
HPW Hydraulic Power Washer
KPL High Pressure Street Washing Unit
HPW-DUST High Pressure Dust Suppression System
PPL High Pressure Pipe Cleaning Unit
HPW-FIRE High Pressure Firefighting System
FP Fire Fighting Piercing Kit
HDF Hydraulic Drilling Fluid Pump
JPL High Pressure Bin Washing System
HSP Hydraulic Submersible Pump



COMPRESSED AIR

HK Hydraulic Piston Compressor
HKL Hydraulic Rotary Vane Compressor
HKR Hydraulic Screw Compressor



MAGNET POWER

HMG PRO Hydraulic Magnet Generator
MAG Lift Magnet
HMAG PRO Hydraulic Magnet



VIBRATION

HVB Hydraulic Vibra
HVD Hydraulic Directional Vibra
HRC Hydraulic Reversal Cylinder



POWER BOOSTING

HPI Hydraulic Pressure Intensifier
HPI-C Hydraulic Pressure Intensifier for Cylinder



KNOW-HOW

Hydraulic Power Take-off (PTO)
Hydraulic Power Unit Technology
De-Icing Technology
Installation Valves
HHK Hydraulic Grinder
HV/HVY Hydraulic Winch / Winch Unit

www.dynaset.com

